

OWNER MANUAL MANUALE D'USO

EVOX JMIX8

- ACTIVE TWO-WAY
ARRAY SPEAKER
WITH INTERNAL DIGITAL MIXER
- DIFFUSORE ACUSTICO ("ARRAY")
AMPLIFICATO A DUE VIE
CON MIXER DIGITALE INTEGRATO



**IMPORTANT**

Before connecting and using this product, please read this instruction manual carefully and keep it on hand for future reference.

The manual is to be considered an integral part of this product and must accompany it when it changes ownership as a reference for correct installation and use as well as for the safety precautions.

RCF S.p.A. will not assume any responsibility for the incorrect installation and / or use of this product.

WARNING: To prevent the risk of fire or electric shock, never expose this product to rain or humidity.

CAUTION: to prevent electric shock hazard, do not connect to mains power supply while grille is removed

SAFETY PRECAUTIONS

1. All the precautions, in particular the safety ones, must be read with special attention, as they provide important information.

2. POWER SUPPLY FROM MAINS

- Appliance coupler or PowerCon Connector® is used to disconnect device from MAIN power. This device shall remain readily accessible after the installation
- The mains voltage is sufficiently high to involve a risk of electrocution: never install or connect this product when its power cord is plugged in.
- Before powering up, make sure that all the connections have been made correctly and the voltage of your mains corresponds to the voltage shown on the rating plate on the unit, if not, please contact your RCF dealer.
- The metallic parts of the unit are earthed by means of the power cord. This is a Class I device and for its use it must be connected to a grounded power source.
- Protect the power cord from damage. Make sure it is positioned in a way that it cannot be stepped on or crushed by objects.
- To prevent the risk of electric shock, never open this product: there are no parts inside that the user needs to access.

3. Make sure that no objects or liquids can get into this product, as this may cause a short circuit. This apparatus shall not be exposed to dripping or splashing. No objects filled with liquid (such as vases) and no naked sources (such as lit candles) should be placed on this apparatus.

4. Never attempt to carry out any operations, modifications or repairs that are not expressly described in this manual.

Contact your authorized service centre or qualified personnel should any of the following occur:

- The product does not function (or functions in an anomalous way).
- The power cord has been damaged.
- Objects or liquids are inside the product.
- The product has been subject to a heavy impact.

5. If this product is not used for a long period, disconnect its power cord.

6. If this product begins emitting any strange odours or smoke, switch it off immediately and disconnect its power cord.

7. Do not connect this product to any equipment or accessories not foreseen.

Do not try to hang this product by using elements that are unsuitable or not specific for this purpose.

IMPORTANT**WARNING****CAUTION**

To prevent the risk of falling equipment, do not stack multiple units of this product unless this possibility is specified in the user manual.

8. RCF S.p.A. strongly recommends this product is only installed by professional qualified installers (or specialised firms) who can ensure correct installation and certify it according to the regulations in force.

The entire audio system must comply with the current standards and regulations regarding electrical systems.

9. Supports and trolleys

The equipment should be only used on trolleys or supports, where necessary, that are recommended by the manufacturer. The equipment / support / trolley assembly must be moved with extreme caution.

Sudden stops, excessive pushing force and uneven floors may cause the assembly to overturn.

10. Hearing loss

Exposure to high sound levels can cause permanent hearing loss. The acoustic pressure level that leads to hearing loss is different from person to person and depends on the duration of exposure. To prevent potentially dangerous exposure to high levels of acoustic pressure, anyone who is exposed to these levels should use adequate protection devices.

When a transducer capable of producing high sound levels is being used, it is therefore necessary to wear ear plugs or protective earphones. See the manual technical specifications to know the maximum sound pressure level.

11. Situate this product far from any heat sources and always ensure adequate air circulation around it.

12. Do not overload this product for a long time.

13. Never force the control elements (keys, knobs, etc.).

14. Do not use solvents, alcohol, benzene or other volatile substances for cleaning the external parts of this product.

Use a dry cloth.

15. Do not put microphones close and in front of speakers, in order to avoid audio feedback ('Larsen effect').

NOTES ABOUT AUDIO SIGNAL CABLES



To prevent the occurrence of noise on microphone / line signal cables, use screened cables only and avoid putting them close to:

- Equipment that produces high-intensity electromagnetic fields.
- Mains cables.
- Loudspeaker lines.

The equipments considered in this manual can be used in electromagnetic environment E1 to E3 as specified on EN 55103-1/2: 2009.

FCC RULES



Note: This equipment has been tested and found to comply with the limits for a Class A digital device, pursuant to Part 15 of the FCC Rules. These limits are designed to provide reasonable protection against harmful interference when the equipment is operated in a commercial environment. This equipment generates, uses, and can radiate radio frequency energy, and if it is not installed and used in accordance with the instruction manual, it may cause harmful interference to radio communications. Operation of this equipment in a residential area is likely to cause harmful interference, in which case the user will be required to correct the interference at his own expense.

Modifications: Any modifications made to this device that are not approved by RCF may void the authority granted to the user by the FCC to operate this equipment.

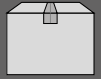

RCF S.P.A. THANKS YOU FOR PURCHASING THIS PRODUCT, WHICH HAS BEEN MADE TO GUARANTEE RELIABILITY AND HIGH PERFORMANCE.

EVOX JMIX8 is a portable active sound system (made of a satellite plus a subwoofer) that combines quality and reliability of RCF transducers with high amplification power. It features eight 2.0" full range transducers in the line source satellite and a deep sounding 12" woofer in a bass reflex enclosure.

INTERNAL 8 CHANNEL DIGITAL MIXER

Taking the EVOX J8 one step further, RCF has added an 8-input Digital Mixer to the system. The onboard processing power of the innovative Z.CORE DSP provides not only full mix functions it includes high-quality instrument FX and AMP simulations. An EVOX iOS/Android-compatible app allows to manage the JMIX8. Adding Bluetooth audio and Hi-Z instrument input, the EVOX JMIX8 combines the quality and reliability of RCF transducers and amplification with a powerful remote controllable 8-channel digital mixer. The system is an optimal portable solutions for live music, DJ mix-sets and also presentations, congresses, other events, etc. .

INNOVATIVE DSP PROCESSING

EVOX DSP processing is the result of many years of experience in line array design combined with innovative and dedicated algorithms. Thanks to the frequency dependent drivers excursion and control of distortion, EVOX DSP processing is capable to guarantee a high output from these small systems. A dedicated vocal processing has been specifically studied for speech reproduction during presentations or conferences.

RCF TECHNOLOGY

EVOX JMIX8 includes high technology RCF transducers. The ultra-compact full-range 2" driver can handle extremely high sound pressure levels and power. The high excursion woofers are able to extend to the lowest frequencies and offer a quick and precise response up to the crossover point. Specific attention has been dedicated to mid-low frequencies as well.

CONTROLLED DIRECTIVITY PATTERN

EVOX array design features a constant horizontal directivity coverage of 120°, offering a perfect listening experience to the audience. The vertical array design is progressively shaped to guarantee a correct listening from the first row.

MULTIFUNCTIONAL TOP HANDLE

The top steel plate joins the handle and the insert for pole mounting. A rubber hand grip has been added for great portability.

CLASS D AMPLIFICATION

EVOX J8 includes a high power two-way class D amplifier with DSP controlled crossover.





Remove the rubber band and take out the satellite



Screw the lower part of the satellite speaker stand (the pole) into the subwoofer insert for pole mounting.



Screw the telescopic upper part of the satellite speaker stand into its lower part.

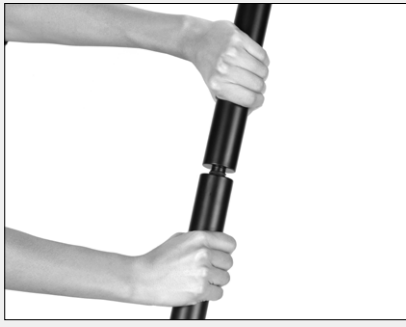

Loose the stand bolt, adjust the satellite speaker height from the floor and tighten the bolt again, then insert the satellite speaker into its complete stand and aim it correctly.

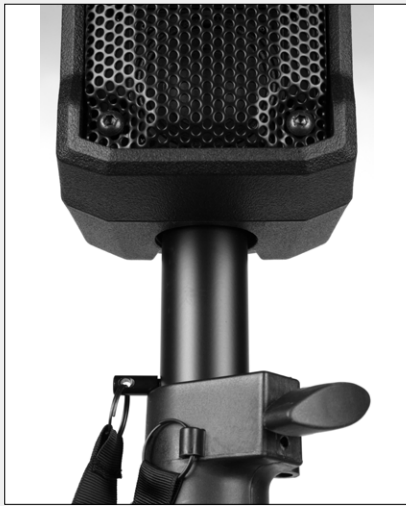

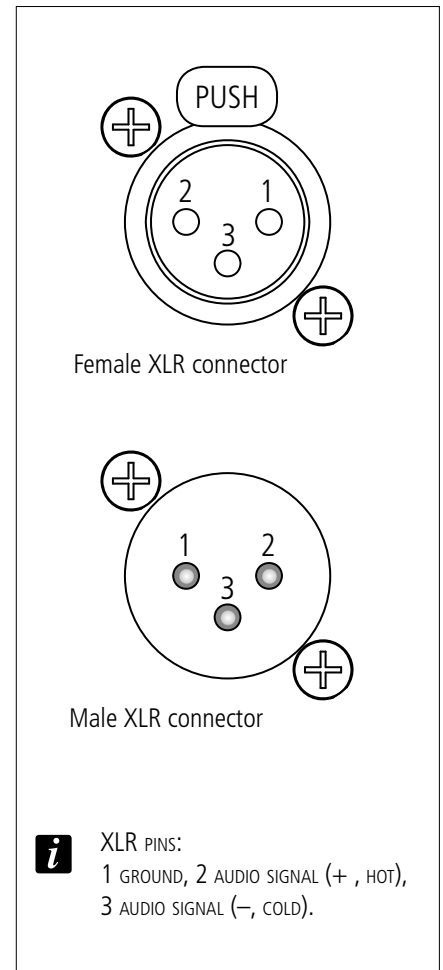
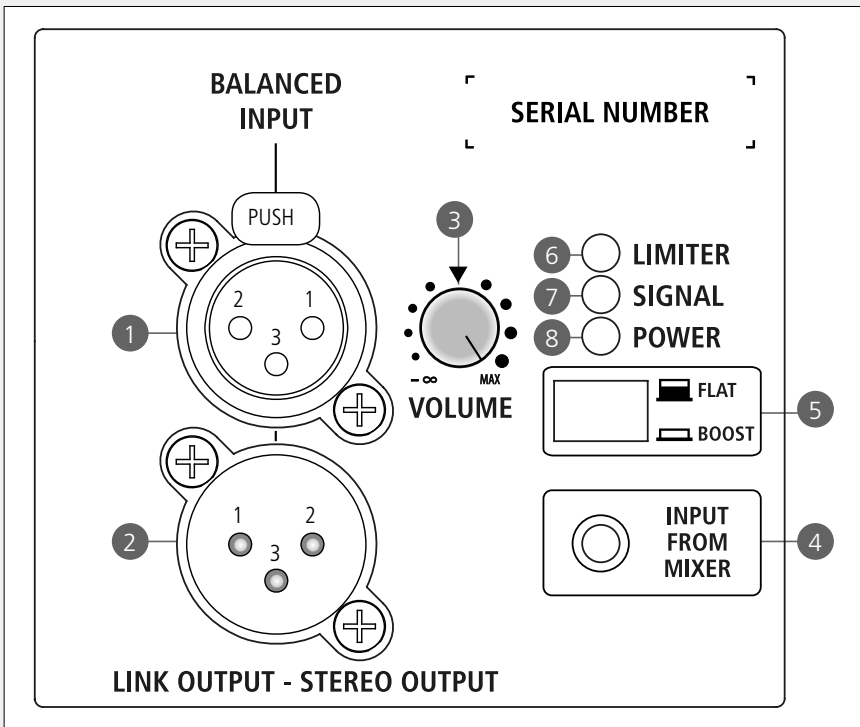

1 Balanced audio input (female XLR connector)

2 Link output - Stereo Output (male XLR connector).

This output is linked in parallel with the audio input and is useful to connect another speaker (only when the INPUT FROM MIXER 4 LED is off). Otherwise it works by default as the mixer "R" output channel.

3 System volume control

4 INPUT FROM MIXER

When the LED is OFF, the digital mixer is disabled and the signal input is coming from the XLR input 1. In this case the male XLR output works as a regular parallel audio output. When the LED is ON, the signal input is coming from EVOX JMIX8 digital mixer. In this case, the male XLR output becomes by default the R output to an additional EVOX J8. (The mixer offers a function (SWAP LR) to swap the L-R output channels swapping them to "R-L";

See section 11 on the Digital Mixer Instruction Chapter).

5 FLAT / BOOST switch

FLAT (released switch, normal mode): no equalisation is applied (flat frequency response).

BOOST (pushed switch): 'loudness' equalisation, only recommended for background music at low volume levels.

6 LIMITER LED

The internal amplifier is provided with a limiter circuit to prevent clipping and overdriving transducers. It blinks when the signal level reaches the clipping point, causing the limiter intervention. If it is steady lit, the input signal level is excessive and should be reduced.

7 SIGNAL LED

When lit, it indicates the signal presence at the audio input.

8 STATUS LED

When blinking, it indicates the internal protection intervention due to thermal drift (the amplifier then gets to a "mute" status).



XLR PINS:

1 GROUND, 2 AUDIO SIGNAL (+, HOT),
3 AUDIO SIGNAL (-, COLD).

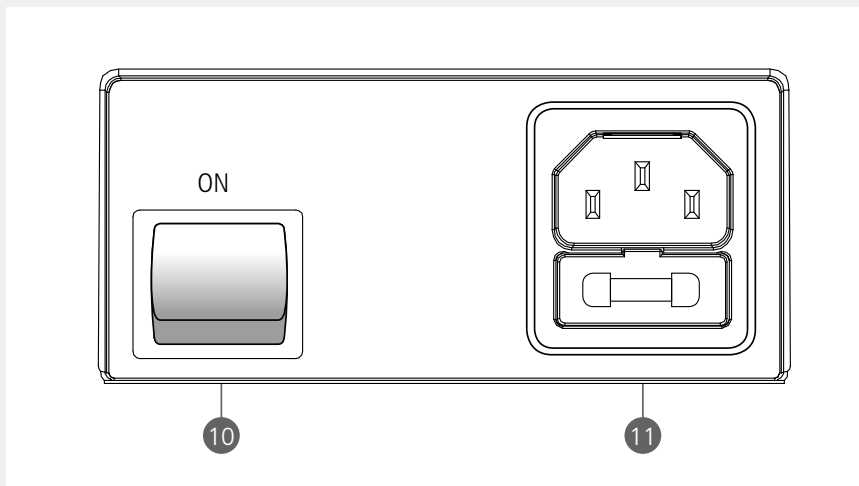
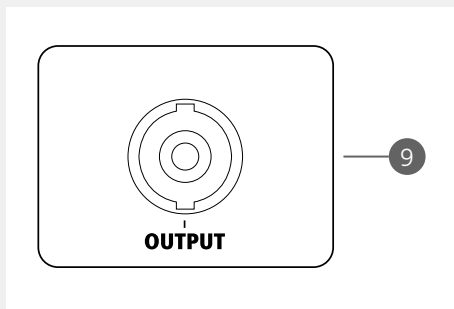

9 Amplifier output to link the satellite speaker.

10 POWER switch

Push it to turn ON / OFF the amplifier.

Before switching the amplifier ON, check all the connections and turn fully counterclockwise ($-\infty$) the volume control 3.

11 VDE Inlet with fuse.

100-120V~ T 6.3 A L 250V

220-240V~ T 3.15 A L 250V

Before connecting the power cord, check if the A/C Power corresponds to the voltage indicated on the rating plate on the unit. If not, please contact your RCF dealer.

Connect the power cord only to a A/C Power socket outlet with a protective earthing connection.

When replacing the fuse, refer to the silkscreen indications.

WARNING: the VDE Power Connector is used to disconnect the system from the power supply network. It must be always easily accessible after the installation and during the use of the system.

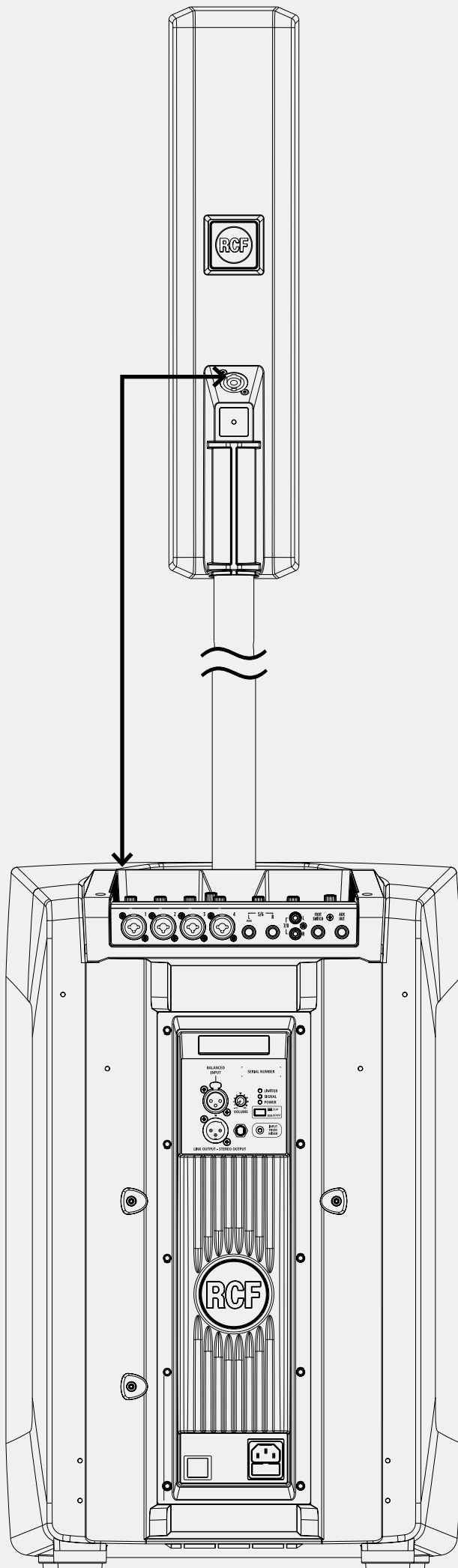

IMPORTANT:

BEFORE TURNING THE AMPLIFIER ON, LINK THE SUBWOOFER AMPLIFIER OUTPUT TO THE SATELLITE SPEAKER INPUT (AS SHOWN IN THE FIGURE)

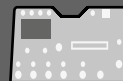

INPUT PANEL

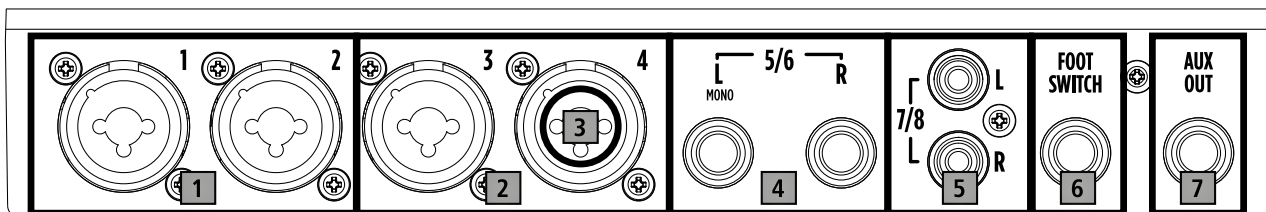

1 MIC/LINE Combo inputs 1 and 2 are provided with switchable 48V Phantom Power; connect here microphones (XLR) or line sources (TRS jack). It is possible to connect here Condenser or Electret microphones thanks to the available 48V phantom power.

2 MIC/LINE Combo inputs 3 and 4; connect here dynamic microphones (XLR) or line sources (TRS jack).

3 HiZ LINE input. LINE input 4 is provided with selectable Hi Impedance input, which offers optimum reproduction of a guitar or bass guitar even if with passive pick up. The instrument connected to Line input 4 can take advantage of the MFX section (see section 16 of this manual).

4 Stereo Line input 5 and 6; connect a stereo line source to these TS Jack pair. If connected alone the input line 5(L) behaves like a mono input.

5 Stereo Line input 7 and 8; connect a low level (-10dBV) stereo line source to these RCA unbalanced inputs.

6 Footswitch; it allows usage of a dual footswitch, one function can be assigned on the tip contact and one to the ring contact. Find all the possible assignable function in the section 16 of the mixer surface description.

7 AUX OUT; this is a balanced output for the auxiliary send available on each input channel.

DISPLAY MENU INFORMATION

All the functions available on the EVOX JMIX8 system integrated mixer can be operated from the operating display.

The select buttons: INPUT, OUTPUT, HOME, SYSTEM, MFX, FX give access to all the parameter pages on the LCD display.

Navigate into the display menu by pressing the PARAMETER SELECT buttons (12) to select the parameters to edit, and rotate the EDIT encoder **13** to change those values. Some settings require a push of EDIT encoder to confirm value or function change, and a display message will appear in this eventuality.

All display pages are usefully shown in the panel silkscreen:

INPUT	OUTPUT	HOME	SYSTEM	MFX (ch.4)	Z.CORE DSP FX
LEVELS	MAIN SET	VU METERS	LOAD	SETTINGS (A/B)	01-40 REVERBS
3-BAND EQ	MAIN 7-BAND EQ	INFO	SAVE	AMP SIMULATION	41-60 DELAYS
PREAMP	AUX SET	MIXER ON/OFF	SETTINGS	MODULATION	61-80 MODULATIONS
DYNAMICS	AUX 7-BAND EQ		FOOTSWITCH	DELAY	

FRONT PANEL

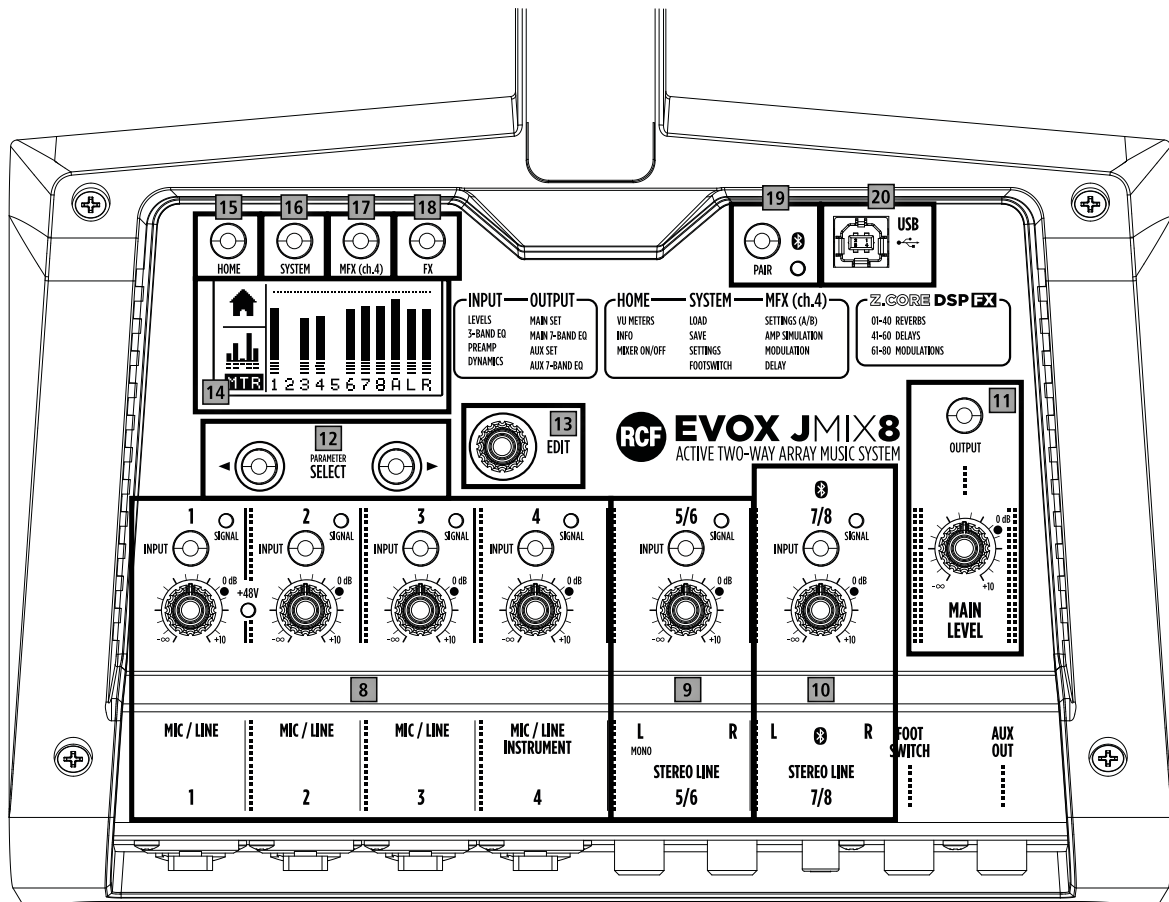

8 MONO input channels; the MIC/LINE 1 to 4 input channels provide a level knob and an INPUT button. The small yellow point named 0dB indicates the “unity gain” level of the channel. The SIGNAL LED lights up in green when a signal louder than -40dB is applied to the input. The red LED located between the channels 1 and 2 knobs indicates that the +48V phantom power is activated on those channels (see section 16). Pressing the HOME button (15) the METER page will open showing the level metering of signal inputs and outputs. The INPUT button, repeatedly pressed, gives access to the four available display parameters pages (14). The number on the display upper left corner indicates which input channel is being edited.

INPUT Menus for mono channels:

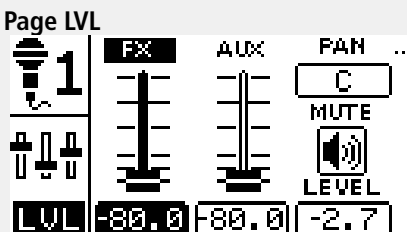

LEVELS (LVL): this menu page gives access to FX send and AUX send levels for the specified input. PAN and channel MUTE controls are shown on the right side. The small rectangular boxes on the bottom line, from left to right, indicate the absolute levels of FX send, AUX send and Channel Level.

Page EQ

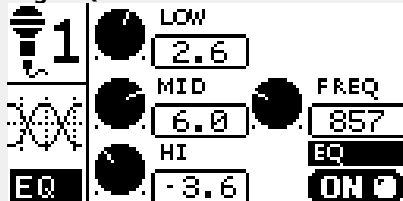

EQUALIZATION (EQ): this menu page gives access to EQ parameters; every input channel is provided with a three band EQ: LOW and HIGH bands are +/-12dB shelving EQs with reference frequency at 125Hz and 6.0kHz. The MID BAND EQ provide selectable frequency from 50Hz to 12kHz and +/-12dB gain. A global EQ ON/OFF control is available on the lower right.

Page PRE

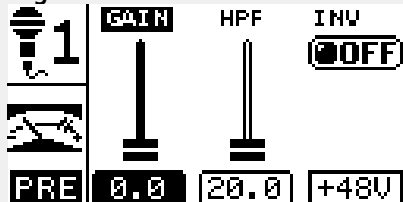

PREAMP GAIN (PRE): an input GAIN parameter allows to add up to 30dB to the input signal. HPF performs a selectable High Pass Filter from 20Hz to 1kHz. INV ON/OFF permits to invert the polarity of the input signal. In the channel 1 and 2 PRE pages a dedicated box indicates the activation of +48V phantom power (see section 16).

Page DYN

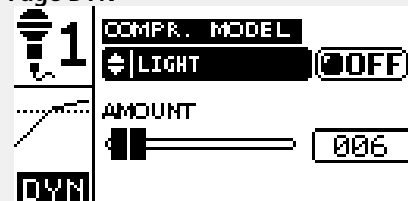

DYNAMIC (DYN): COMPRESSOR; MIC/LINE inputs 1 to 4 are provided with a single control compressor. The cursor indicates the depth of the compressor intervention. A dedicated box toggles the compressor ON and OFF. Up to 6 different presets can be selected from the Compressor Model list:

1. LIGHT
2. HEAVY
3. VOCAL
4. BASS
5. ACOUSTIC
6. DRUM

LINE input 4 is provided with selectable Hi Impedance input, which is available for passive instruments such as guitars or bass guitars. The instrument connected to Line input 4 can also take advantage of the MFX section (see dedicated chapter 17). Page PRE for LINE input 4 changes slightly:

Ch.4 LINE IN Page PRE

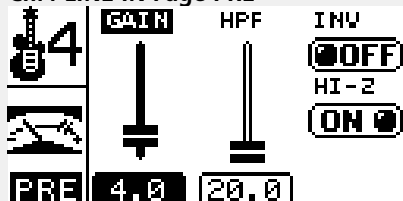

A dedicated box, labeled HI-Z, allows to activate and deactivate the High Impedance input on LINE 4: HI-Z ON/OFF.

9 STEREO LINE input channel 5/6: connect to these TS jacks any analog stereo source. Control the stereo channel level with the dedicated knob: The SIGNAL LED lights up in green when a signal louder than -40dB is applied to the input. Pressing the INPUT button gives the access to display menus:

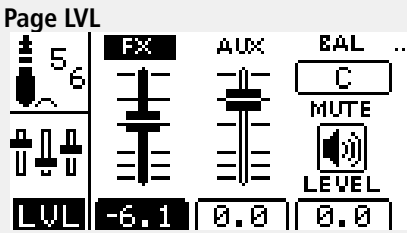

LEVELS (LVL): as for the MONO channels, this menu page gives access to the channel FX send, AUX send. BAL (balance) and channel MUTE controls are shown on the right side. When pressed, the MUTE button also affects FX and AUX sends. The small rectangular boxes on the bottom line, from left to right, indicate the absolute levels of FX send, AUX send and Channel Level. All the other pages are same as MONO channels input.

10 STEREO LINE 7/8: connect to these RCA connectors any low level analog stereo source (-10dBV). Control the stereo channel level with the dedicated knob: the SIGNAL LED lights up in green when a signal louder than -40dB is applied to the input. Pressing the INPUT button gives the access to display menus. The control pages of channels 7/8 are same as channel 5/6 except for the **PRE** page:

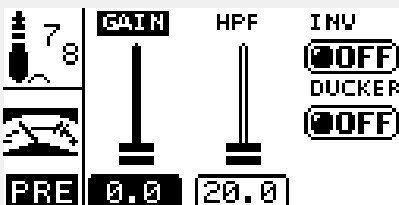

From the dedicated box called DUCKER it is possible to activate a ducker gate on channels 7/8. The control key for the ducker is always the signal present on MIC input 1. Channel 7/8 is also used for Bluetooth audio input.

11 MAIN LEVEL: MAIN LEVEL controls the master signal level; it provides a control level knob and an OUTPUT button. The small yellow point named 0dB indicates the “unity gain” level of the Main Mix. Press the button HOME (15) to show the METER page which includes level metering of L-R output. Pressing the OUTPUT button gives access to the following pages:

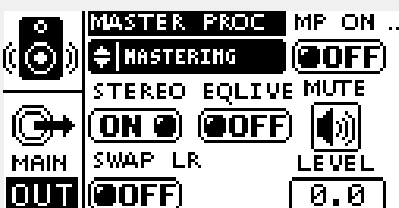

OUT page: in this page a drop down menu shows one of the four selectable mastering presets. Rotate and press the EDIT encoder to select a different mastering preset:

1. MASTERING
2. MASTER BOOST
3. LOUD & PROUD
4. HI-FI

These presets combine the action of an Exciter and a Maximizer to apply nice dynamic and frequency response improvement to the Master signal.

A dedicated box MP ON/OFF permits to turn on and off this feature.

The STEREO box ON/OFF allows to select the chosen system configuration: using the EVOX JMIX8 as a stand alone speaker, the STEREO box has to be set to OFF. Using EVOX 8 JMIX8 + EVOX J8 as a stereo configuration, the STEREO BOX has to be set to ON. In

this case the EVOX JMIX8 outputs the LEFT channel and the EVOX J8 outputs the RIGHT channel. If the environment or the setup does not permit the correct positioning of EVOX JMIX8 as left channel and EVOX J8 as right channel, it is possible to reverse the stereo image using the box called SWAP LR:

SWAP LR OFF: EVOX JMIX8 LEFT – EVOX J8 RIGHT

SWAP LR ON: EVOX JMIX8 RIGHT – EVOX J8 LEFT

EQLIVE

This control enables a specific contour which is optimized for live use of musical instruments, rather than prerecorded material. You can enable this mode at your choice. The EQLIVE setting affects both LEFT and RIGHT outputs, therefore it is activated also on the external EVOX J8 which may be connected to the LINK OUT XLR output; the AUX output is not affected, unless its routing is set to Link Out mode.

A MUTE box completes the set of controls on this page. Selecting the MUTE box interrupts the signal flow through the MAIN stereo channel. The numeric window in the lower right display corner shows the nominal level of the MAIN LEVEL knob. The small round point on the knob scale indicates the 0.0dB level.

MAIN GEQ page: this page gives access to the 7 band Graphic EQ available on MAIN channel. Select each single band of the EQ using the "PARAMETER SELECT" buttons [12] and rotate the EDIT encoder to change value. A value box shows the variation in dBs of the selected band. A dedicated box permits to turn ON and OFF the entire EQ.

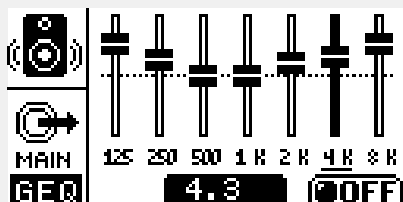

AUX OUT page: this page gives access to the master level control of the AUX bus. Select "AUX" from the ROUTING drop-down menu for the regular use of the AUX send. PRE/POST ON/OFF box allows to derive the AUX signal before or after the channel level control. Set this control to OFF for AUX PRE and ON for AUX POST. FX RTN ON/OFF box permits to assign the internal effect return to the AUX bus. The MUTE box, if selected, mutes the AUX bus output.

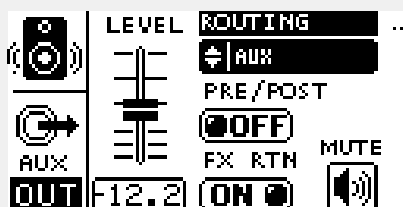

Select "MAIN L-R" from the ROUTING drop-down menu, permits to assign to the AUX bus the MAIN MIX signal, summed in mono.

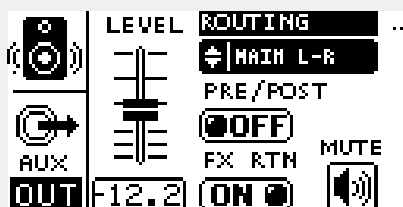

Select "LINK OUT" from the ROUTING drop-down menu, it allows to create an available link connection with a further EVOX J8 from the AUX OUT balanced jack. This setting permits to create a large EVOX setup composed by one EVOX JMIX8 plus up to three EVOX J8. (See page 42: EVOX JMIX8 CONFIGURATION).

When the "LINK OUT" function is selected from the ROUTING menu, the display will show the following message: "AUX CONTROL DISABLED WHEN LINK OUT ACTIVE"

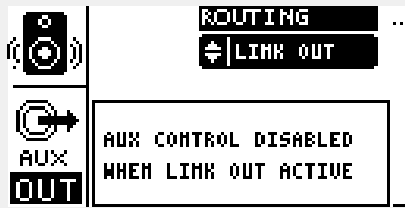

AUX GEQ page: this page gives access to the 7 band Graphic EQ available on AUX bus. Select each single band of the EQ using the "PARAMETER SELECT" button and rotate the EDIT encoder to change value. A value box shows the variation in dBs of the selected band. A dedicated box permits to turn ON and OFF the entire EQ.

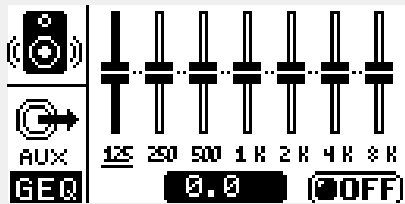

15 HOME Button:

The HOME button gives access to three pages: MTR Page, INFO Page and "I/O" Page.

MTR page: on the METER page it's possible to view all the mixer signal levels: Inputs from 1 to 8, AUX and MAIN L/R.

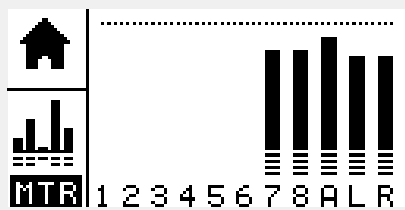

Pressing the HOME button again gives access to the INFO page where the following is shown:

FIRMWARE: firmware version - x.xx
 BT ID: Bluetooth Identification – 123x
 BT STAT: Bluetooth status - (OFF/PAIRING/ONLINE)
 USB STAT: USB connection status - (OFFLINE/ONLINE)

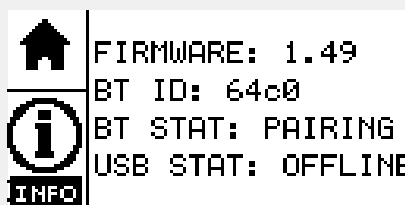

Pressing the HOME button again gives access to the "I/O" MIXER ENABLE DISABLE page.



This menu allows to disable the mixer in an EVOX JMIX8 system. Turn the EDIT encoder counterclockwise to change the menu line from MIXER ENABLE to MIXER DISABLE, press the EDIT encoder, a display message will appear:

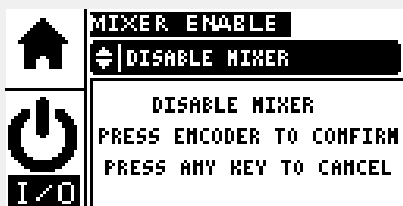

DISABLE MIXER – PRESS ENCODER TO CONFIRM – PRESS ANY KEY TO CANCEL

By pressing the EDIT encoder again, the mixer is disabled and the LCD display backlight will switch off in 3 seconds.

Now the mixer is disabled, and the EVOX JMIX8 can be used like a conventional active speaker using the XLR connection located on the subwoofer back panel as mono input. To enable the mixer again, turn clockwise the EDIT encoder, the display will switch on again, press the EDIT encoder and a display message will appear:

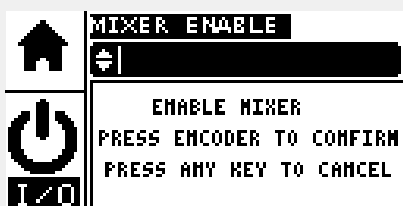

ENABLE MIXER – PRESS ENCODER TO CONFIRM – PRESS ANY KEY TO CANCEL

Pressing the EDIT encoder the EVOX JMIX8 mixer is enabled again and the system turns to full operation.

16 SYSTEM button:

Pressing the button once gives access to the LOAD SHOW page;

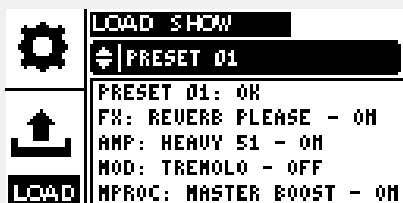

It is possible to load a pre-saved SHOW from the dedicated menu. A SHOW preset includes all the mixer parameters except the INPUT and MAIN level. These parameters are absolute values and can be controlled via pot knobs only. The possible selection is between 10 presets (01 to 10) plus a special preset n°11 called RESET MIXER. Loading the RESET MIXER preset brings the mixer to a default setting.

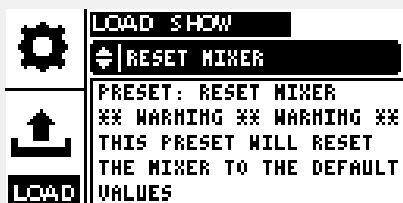

To load a preset rotate the EDIT encoder clockwise, select the chosen preset and confirm the selection pressing the EDIT encoder. A message will appear:

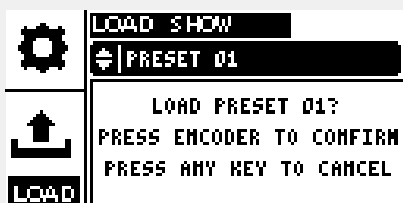

LOAD PRESET "XX" – PRESS ENCODER TO CONFIRM - PRESS ANY KEY TO CANCEL
 Press the EDIT encoder again to load the selected preset, or press any key to cancel the operation.
 When a preset is loaded, this information will appear in a dedicated area on the LOAD SHOW page.

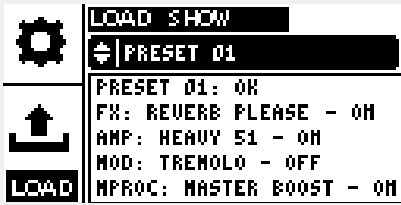

SAVE SHOW page:

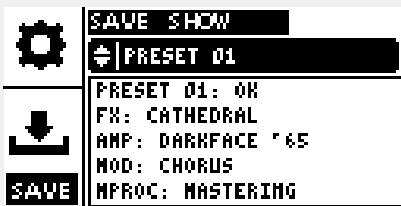

The SAVE SHOW page permits to save all the parameters of the mixer in a preset. Again, the INPUT and MAIN level are excluded from the preset data, they are absolute values and can be controlled via pot knobs only.
 Select a preset location from the dedicated menu rotating the EDIT encoder, then press the EDIT encoder; a display message will appear:

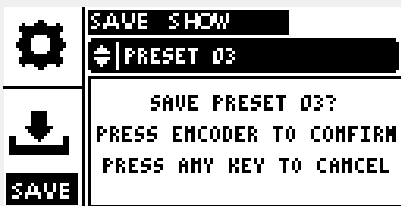

SAVE PRESET "XX" – PRESS ENCODER TO CONFIRM - PRESS ANY KEY TO CANCEL
 By pressing the EDIT encoder, the preset will be stored. If the selected preset is already in use a message will appear:

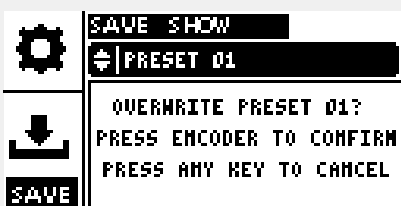

OVERWRITE PRESET "XX" – PRESS ENCODER TO CONFIRM - PRESS ANY KEY TO CANCEL
 By pressing the encoder again will store the preset, while pressing any key will cancel the operation.

By pressing the SYSTEM button once more, the SET page is shown:
 The SET page allows to access to some important mixer settings.
 The boxes from top left to bottom:

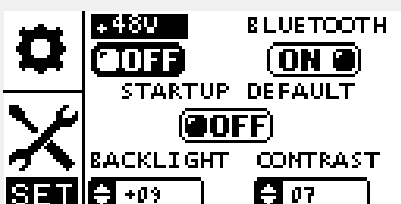

+48V ON/OFF: enables or disables +48 V phantom power on MIC inputs 1 and 2.

BLUETOOTH ON/OFF: enables or disables the Bluetooth connection both for audio streaming and control.

STARTUP DEFAULT ON/OFF: if this box is set to OFF when the system is switched on, the mixer keeps its last status when turned off. If the box is set to ON, the mixer is switched on with a default configuration.

The BACKLIGHT and CONTRAST boxes permit to set brightness and contrast of the LCD display.

Pressing the SYSTEM button again gives access to the FSW page dedicated to assign footswitch functions (see section 6 in the input panel description).

FSW page:



The FSW page is composed of three menus: TIP FUN, RING FUN, POLARITY

1. TIP FUN (Tip jack contact function) including:

- MUTE OUTS
- FX ON/OFF
- MFX CHAN A/B
- MFX ON/OFF
- MFX AMP ON/OFF
- MFX MOD ON/OFF
- MFX DLY ON/OFF
- SHOW NEXT
- SHOW PREV
- MASTER PROC ON/OFF

2. The RING FUN (Ring function) provides the same selections as for TIP FUN menu.

3. A POLARITY menu allows to change the initial status of the connected footswitch between NORMALLY CLOSED and NORMALLY OPEN.

17 MFX button:

The MFX button controls the menu related to the MFX chain present on LINE input 4.

Two local settings of the whole MFX are available, called Channel A and B. It is possible to switch between A and B using the footswitch (see dedicated function).

The SET page allows to select between FX channel A or B with the dedicated knob icon.

MFX ON/OFF box allows to turn on and off the MFX chain. The AMP, MOD, DLY ON/OFF boxes located in the bottom line of the display turn on and off individually the components of the MFX chain:

AMP (Guitar & Bass amp simulator), MOD (modulations effects), DLY (delay).

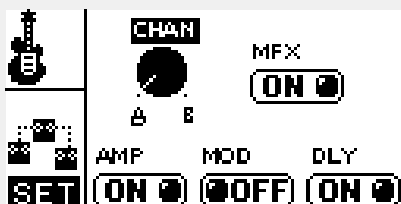

Pressing the MFX button again gives access to the AMP page:



AMP page: using the AMP MODEL menu on the bottom of the display, it is possible to select one of the 15 amp simulations by OVERLOUD™:

1. DARKFACE '65
2. JAZZ C
3. ROCK'64
4. ROCK 800
5. ROCK 900
6. TOP 30
7. MODERN
8. BASSAMP
9. BASSMATE
10. MARKBASS 1
11. MARKBASS 2
12. SLO 88 CRUNCH
13. SLO 88 LEAD
14. OVERANGE 120
15. HEAVY 51

Rotate the EDIT encoder to select an AMP Simulation model.

The top line of rotary controls allows to change the parameters of the selected AMP model: DRV (Drive), BASS (Bass frequencies), MID (Mid frequencies), TRB (Treble-High frequencies).

The AMP ON/OFF box allows to bypass the amp simulator.

Press MFX again to access to MOD page:

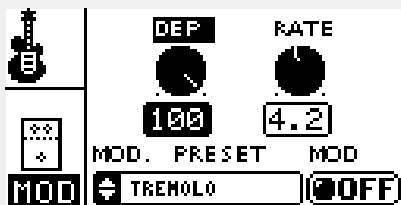

MOD page: use the MOD. PRESET menu on the bottom of the page to select a modulation program between:

1. CHORUS
2. FLANGER
3. TREMOLO

Rotate the EDIT encoder to select a modulation type.

The two rotary controls allow to change the parameters of the selected modulation preset: DEP (Depth) from 0 to 100%, and RATE (rate) in Hz.

The MOD ON/OFF box allows to bypass the modulation module.

DLY page:



The Delay page shows three rotary controls to edit the DELAY effect: LEV (level), TIME (Delay time) in ms, FDBK (Delay feedback). Set these parameters to create the favorite delay effect. The DLY ON/OFF box allows to bypass the delay module.

18 FX button:

Pressing the FX button gives access to the internal effects edit page.

FX PRESET menu allows to select the FX presets:

Select a preset rotating the EDIT encoder and confirm the selection pressing it. The ON/OFF box permits to switch the effect send (FX) on and off.

Each program shows two editable parameters and an effect return level control. The editable parameters for REV programs are:

DEC (sec) – Decay in seconds

DAMP – Frequency Damping

01 – 40 – REVERBS

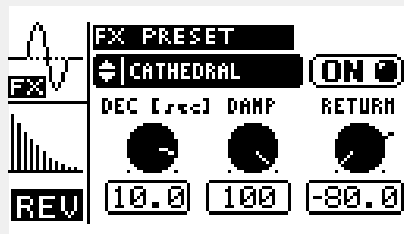

For DLY programs:

TIM (ms) – time in milliseconds

FDBK – Feedback

41 – 60 – DELAYS

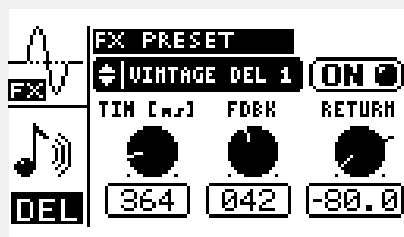

For MOD programs:

RATE – rate (in Hz)

DEPTH – depth

61 – 80 – MODULATIONS

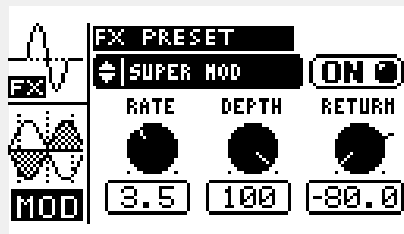

19 PAIR button.

Pressing the PAIR button initiates the Bluetooth discovery sequence, required when a new pairing operation has to be performed on a smartphone, tablet or notebook. The green LED will blink as long as a Bluetooth device is associated. When the device is connected, the green LED will be steadily lit. Now it is possible to control the EVOX JMIX8 system via the Android or iOS app. Furthermore, a Bluetooth audio streaming is enabled to stereo channel 7/8 (see section 10 of this chapter)

20 USB.

The "type B" USB connector is used for future firmware upgrades.



EVOX JMIX8

ACOUSTICAL

Frequency response	40 Hz - 20.000 Hz
Maximum sound pressure level	128 dB
Horizontal coverage angle	120°
Vertical coverage angle	30°
Subwoofer transducer	12", 2.5" voice coil
Satellite transducers	8 x 2", 1.0" voice coil

AMPLIFIER / DSP

Amplifier power (low frequencies)	1000 W (peak)
Amplifier power (high frequencies)	400 W (peak)
Input sensitivity (LINE)	+4 dBu
Crossover frequency	220 Hz
Protections	thermal drift, RMS
Limiter	software limiter
Cooling	convective
Operating voltage	115 / 230 V (according to the model), 50-60 Hz
Inrush current	10,1 A (According to EN 55013-1:2009)

SUBWOOFER PHYSICAL

Height	2350 mm (92.5")
Width	350 mm (13.77")
Depth	450 mm (17.71")

SATELLITE PHYSICAL

Height	501,2 mm (19,73")
Width	113,9 mm (4,48")
Depth	120,5 mm (4.74")

ENTIRE SYSTEM PHYSICAL

Minimum height of the system	1974 mm (77,7")
Maximum height of the system	2284 mm (89,9")
Net weight	24,4 Kg (53,8 lbs)
Cabinet	PP composite

ONBOARD DIGITAL MIXER SPECIFICATIONS



Mic Input	4
Phantom Power	yes (Ch 1-2)
Mono Line Input	4
Stereo Line Input	2
Selectable HiZ Inputs	1
Compressors	4 (Ch 1-4)
Aux Output	1
USB Device	1
Internal Fx	1 x Z-CORE DSP FX
Hipass Filter	All channels from 20Hz to 1kHz
Eq for Mono Channels	3 bands (Shelving High and Low, Semi-parametric Mid)
Eq for Stereo Channel	3 bands (Shelving High and Low, Semi-parametric Mid)
Aux	1 (pre/post)
Fx to Aux	1
Aux Master	1

Nominal Output Level	Main Out	+4 dBu
	Aux Send	+4 dBu
Maximum Output Level	Main Out	18,8 dBu
	Aux Out	18,8 dBu
Output Impedance	Aux Out	150 Ohm
Input Impedance	Line In	10 KOhm
	XLR In	3,4 KOhm
	TRS In	11 KOhm
	HiZ In	1 MOhm
Equivalent Input Noise	dB	-114
Input HPF	cutoff	from 20Hz to 1kHz
Eq	High @ 6 kHz	±12 dB
	Mid sweepable (50Hz – 12kHz)	±12 dB
	Low @ 125Hz	±12 dB
Frequency Response	±0.5 dB	20-20kHz
	Bit Depht	24 bit
	sample rates	44.1 / 48 kHz
Internal Effects	DSP	32 bit floating point

EVOX JMIX8 CONFIGURATIONS

EXTERNAL MIXER WITH EVOX J8
(mono output)

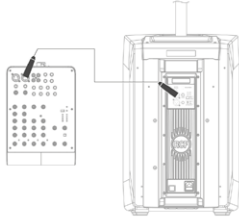

2 X EVOX J8 WITH EXTERNAL MIXER
(stereo output)

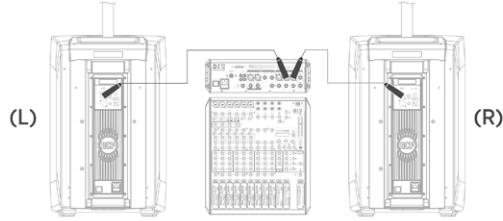

EVOX JMIX8
(mono)

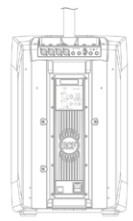

2 X EVOX J8 WITH EXTERNAL MIXER
(mono output)

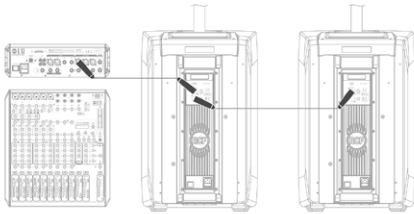

EVOX JMIX8 WITH STAGE MONITOR
(mono)

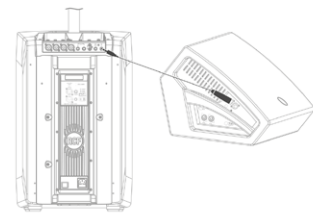

EVOX JMIX8 + EVOX J8
(stereo output)

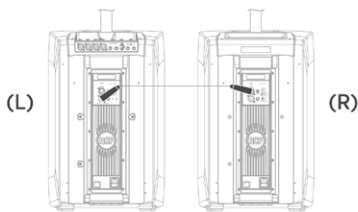

3 X EVOX J8 + 1 X EVOX JMIX8
(stereo output)

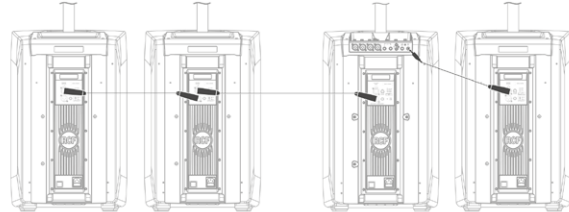

EVOX JMIX8 + EVOX J8 + STAGE MONITOR

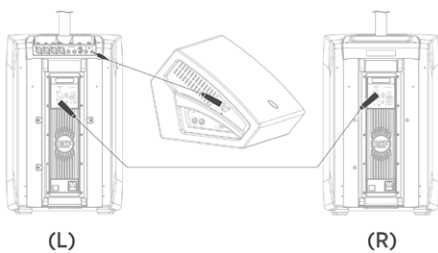

LARGE J SYSTEM

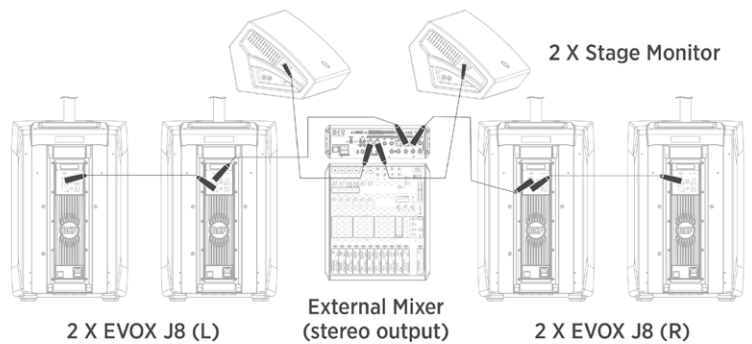

EVOX J MIX8 BLOCK DIAGRAM

RCF EVOMIX – BLOCK DIAGRAM

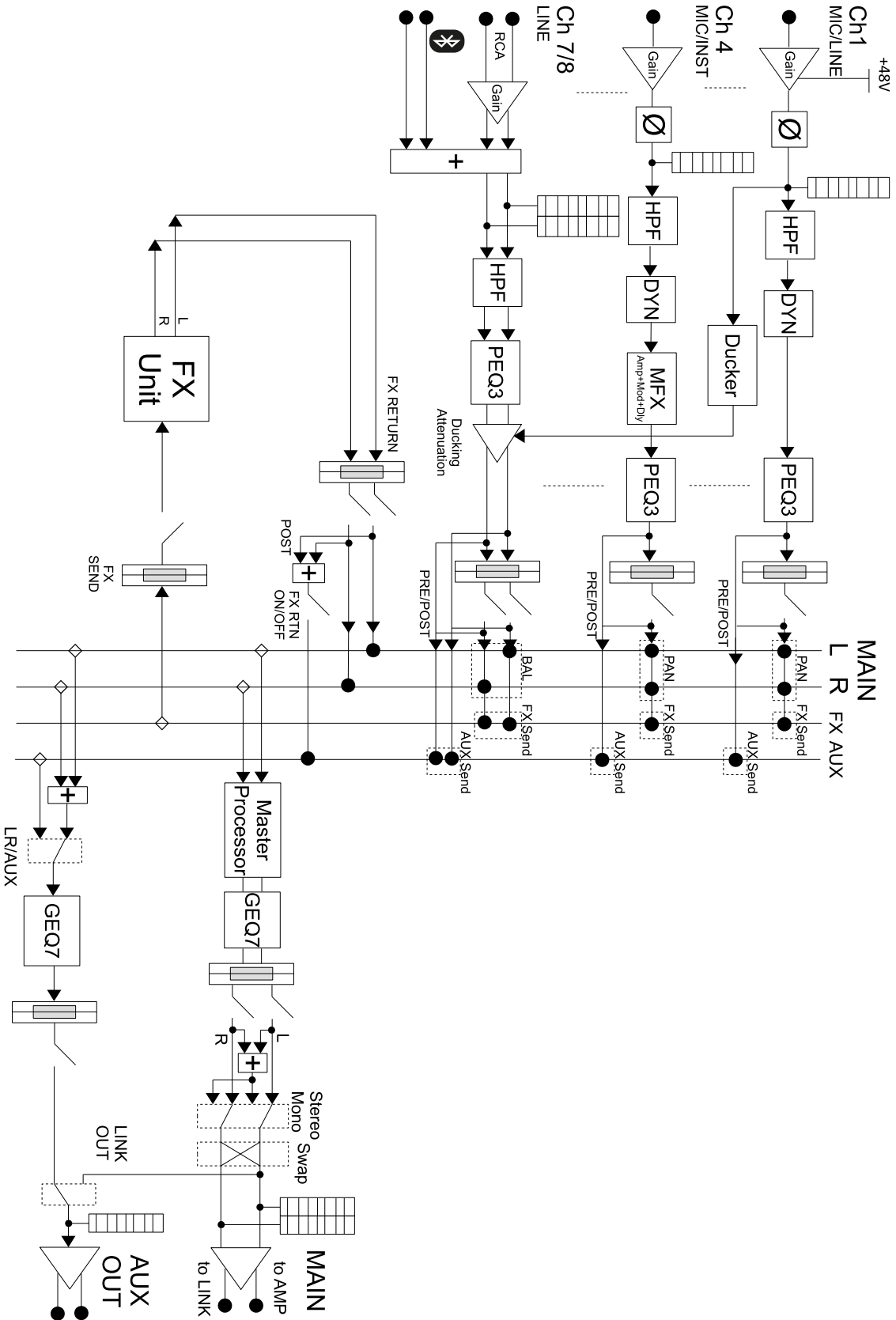



www.rcf.it

RCF S.p.A.

Via Raffaello Sanzio, 13
42124 Reggio Emilia - Italy
Tel +39 0522 274 411
Fax +39 0522 232 428
e-mail: info@rcf.it